



深圳路盛源科技有限公司

SHENZHEN ROADSUNNY TECHNOLOGY CO., LTD.

客户承认书

SPECIFICATION FOR APPROVAL

CUSTOMER/客户: 日本海渡电子有限公司

FILE NO./认证号: _____

PART NO./物料号: 0901000

MODEL NO./产品型号: RS-090100001

Product name/产品名称: 9V1A日规 (5.5*2.5*10MM直头)

PRODUCT NO./产品编号: _____

MAINFRAME MODEL/主机型号: _____

MARK 修改标记	REVISED CONTENT 修改内容	APPROVED & DATE 认可日期
REV:01	首次发行	2023.6.8

AUTHORIZED SIGNATURE & COMPANY CHOP/客户认可签回	

DATE/日期	2023.6.8	EDITION/版本	01	PAGE/页码	1 OF 9
DESIGN/拟制		CHECK/审核		APPROVAL/批准	



目录/Contents

变更履历表.....	2
1. 安规标准SAFETY STANDARD:.....	4
2. 绝缘介电强度(耐压) (S)/DIELECTRIC WITHSTANDING STRENGTH(HI-POT).....	4
3. 输入特性INPUT FEATURE.....	4
3.1 额定输入电压范围RATED INPUT VOLTAGE.....	4
3.2 额定输入频率RATED INPUT FREQUENCY.....	4
3.3 最大输入电流INPUT CURRENT (MAX).....	4
3.4 最大浪涌电流INRUSH CURRENT.....	4
3.5. 平均效率(Average Efficiency)	4
4. 输出特性OUTPUT FEATURE.....	4
5. LED指示LED indicator.....	5
6. 保护Protection.....	5
6.1 输出短路保护SHORT-CIRCUIT PROTECTION.....	5
6.2 过电流保护Over current protection.....	5
6.3 输入保护Input protection device.....	5
7. 环境条件ENVIRONMENTAL CONDITIIONS.....	5
7.1 操作条件OPERATING.....	5
7.1.1 操作温度Operating Temperature.....	5
7.1.2 相对湿度Relative Humidity.....	5
7.1.3 振动Vibration.....	5
7.1.4 冷却Cooling.....	5
7.2 非操作条件NON-OPERATING.....	6
7.2.1. 存储环境温度Storage Temperature.....	6
7.2.2. 振动和冲击Vibration and Shock.....	6
8. 电磁兼容性标准EMC STANDARDS.....	6
9. 可靠性及品质控制RELIABILITY AND QUALITY CONTROL.....	6
9.1 烘烤1BURN-IN.....	6
9.2 元件温度要求(S)COMPONENT DERATING.....	6
9.3 平均无故障时间MTBF.....	6
10. 绝缘阻抗INSULATION RESISTANCE.....	6
11. 漏电流LEAKAGE CURRENT.....	6
12. 主要测量设备MAJOR MEASURE EQUIPMENT.....	6
13. 外观图EXTERNAL VIEW.....	7
14. 输出线材OUTPUT WIRE.....	8
15. 铭牌NAME PLATE.....	9
16. 包装CASING.....	10

ELECTRICAL PERFORMANCE/电气性能

1. SAFETY STANDARD/安规标准:

The power supply shall be certified by the following international regulatory standards

电源应符合下列的国际标准

	Country	Certified Status	Standard/标准
PSE	Japan(日本)	MEET	电安法

2. DIELECTRIC WITHSTANDING STRENGTH(HI-POT)/绝缘介电强度(耐压) (S):

Primary to Secondary AC3000V, 5mA 1 minute for type test, 3 second for production.

一次侧对二次侧: AC3000V, 5mA标准测试1分钟, 量产测试3秒钟.

3. INPUT FEATURE/输入特性:

3.1 RATED INPUT VOLTAGE:100Vac to 240Vac. 额定输入电压范围从100Vac到240Vac.

INPUT VOLTAGE RANGE: 90Vac to 264Vac. 输入电压范围从90Vac到264Vac.

3.2 RATED INPUT FREQUENCY: 50/60Hz. 额定输入频率50/60Hz.

INPUT FREQUENCY RANGE: 47Hz to 63Hz. 输入频率范围从47Hz到63Hz.

3.3 INPUT CURRENT:0.4A max. at 100-240Vac. 最大输入电流0.4A(输入条件100-240Vac).

3.4 INRUSH CURRENT: 40A max. at 100-240Vac input for a cold start at 25°C.

在冷开机条件下,最大浪涌电流不超过40A(输入条件100-240Vac).

3.5 EFFICIENCY: More than 72% at 115/230Vac input and output full load.

效率高于72%(输入115/230Vac和输出满载条件).

4. OUTPUT FEATURE/输出特性:

RATED OUTPUT/额定输出 (I)	SPEC. LIMIT/规格限定		REMARK/备注
	Min. value	Max. value	
9VDC			
Output regulation/输出电压规格 (I)	8.45VDC	9.55VDC	按承认样品为准
Output load/输出负载规格	0A	1.0A	
Ripple and Noise/输出纹波及噪声 (I)		120mVp-p	AT input Voltage:220Vac
			20MHz Bandwidth 10uF
			Ele. Cap.0.1uF Cer. Cap.
Hold up time/关机维持时间	8mS	-	Input voltage: 100Vac
	16mS	-	Input voltage: 220Vac
Transient response/输出瞬态响应	-	800mV	Output load change from 20% to 80% of MAX. load(1.0A)
Over - shoot.		10 %	Less than 5 % of Normal voltage value.
Rise time.		20mS	The output voltage should rise from 0 volts settle within regulation in less than 20 msec From apply of AC input voltage.
Turn-on time		4S	Dc output turn-on delay time shall less than 4 sec.

ELECTRICAL PERFORMANCE/电气性能

5. LED indicator/LED指示

NO LED indicator/无LED指示

6. Protection./保护

6.1 SHORT-CIRCUIT PROTECTION/输出短路保护:

The power supply shall be protection (hiccupped & power reduced) and no damage shall occur when any output operating in a short circuit condition under any line condition for an indefinite period of time. The power supply shall be self-recovery when the fault condition is removed.

在任何时候,任何输入条件下,当输出操作在短路情况下,电源供应器将进入保护(打嗝或功率下降)模式,当短路故障消失后,电源要能自动恢复正常.

6.2 Over current protection/过电流保护

An over current from the output to return line will not damage the power supply.

来自输出的过电流不至于损坏电源供应器

6.3 Input protection device/输入保护

An adequate internal fuse on the AC input line is provided
一个适当的保险丝为输入提供保护.

7. ENVIRONMENTAL CONDITIONS/环境条件:

7.1 OPERATING/操作条件:

The power supply shall be capable of operating continuously in any mode without performance deterioration in the following environmental conditions.

在下列环境条件下,电源供应器要能够连续操作在各种模式,且不能造成性能的退化.

7.1.1 Operating Temperature: 0°C ~ 40°C with the set of customer/操作温度: 0°C ~ 40°C
配客户的使用设备

7.1.2 Relative Humidity: 20% ~ 80%/相对湿度: 20% ~ 80%

7.1.3 Vibration: 1.0mm, 10-25Hz, 15 minutes per cycle for each axis(x,y,z)
振动: 分别在X,Y,Z方向,1.0mm,10-25Hz,15分钟

7.1.4 Cooling: The power supply will operate with convection cooling, Blocking of vents must not cause damage to the power supply.
电源供应器将操作在对流冷却的环境下,即使将通风口阻塞电源也不允许有任何损伤发生.

ELECTRICAL PERFORMANCE/电气性能

7.2 NON-OPERATING/非操作条件:

The power supply shall be capable of withstanding the following environmental conditions extended periods of time, (put it into normal ambient condition treated for 30 min, The test result must be satisfied with item 2 & 4)

电源供应器要能长期的经受下列的环境条件。(在常温常湿中放置30分钟,产品仍须满足上述第2项和第4项的要求.)

7.2.1 Storage Temperature: $-20^{\circ}\text{C} \sim 70^{\circ}\text{C}$ /存储环境温度: $-20^{\circ}\text{C} \sim 70^{\circ}\text{C}$

Relative Humidity: $10\% \sim 90\%$ /相对湿度: $10\% \sim 90\%$

7.2.2 Vibration and Shock/振动和冲击:

The power supply shall be designed to withstand normal transportation vibration per GB/T4857.10, as it is mounted in the chassis assemble and packed for shipping.

电源供应器装配及出货的包装设计,均要能承受正常运输的振动,并符合GB/T4857.10.

8. EMC STANDARDS/电磁兼容性标准:

Meets the Limits of/测试符合

Fcc class B

EN55032 class B

GB9254-2008, GB17625.1-2012, GB13837-2012

9. RELIABILITY AND QUALITY CONTROL/可靠性及品质控制:

9.1 BURN-IN/烘烤:

The power supply shall undergo a minimum of 4 hours Burn-In test under full load at $35 \sim 40^{\circ}\text{C}$. /电源应在 $35 \sim 40^{\circ}\text{C}$ 和满载条件下烘烤4小时.

9.2 COMPONENT DERATING/元件温度要求(S):

Semiconductor junction temperatures shall not exceed the manufacturer's maximum thermal rating. /半导体结温不允许超过其制造商要求的最大温度值.

9.3 MTBF/平均无故障时间:

50,000 Hour at 25 deg C. /50,000小时在25 deg C.

10. INSULATION RESISTANCE/绝缘阻抗:

INPUT TO OUTPUT: $7\text{M}\Omega$ min. (500VDC) /输入对输出 $7\text{M}\Omega$ 最小 (500VDC)

11. LEAKAGE CURRENT/漏电流:

The leakage current shall be less than 0.25mA for Class II when power supply is operated maximum input voltage and maximum load.

当电源供应器操作在最大输入和最大负载的情况下,其漏电流应小于 0.25mA , 满足Class II等级.

12. MAJOR MEASURE EQUIPMENT/主要测量设备:

A. AC SOURCE/交流输入电源

B. POWER METER/电源功率计

C. ELECTRONIC LOAD/电子负载

D. OSCILLOSCOPE/存储示波器

E. DIGITAL MULTIMETER/数字式万用表

G HI-POT TESTER/耐压测试仪

H INSULATION RESISTANCE TESTER/绝缘电阻表

EXTERNAL VIEW/外观图

MECHANICAL DIMENSION (UNIT IN mm)

外形尺寸 (单位: mm)

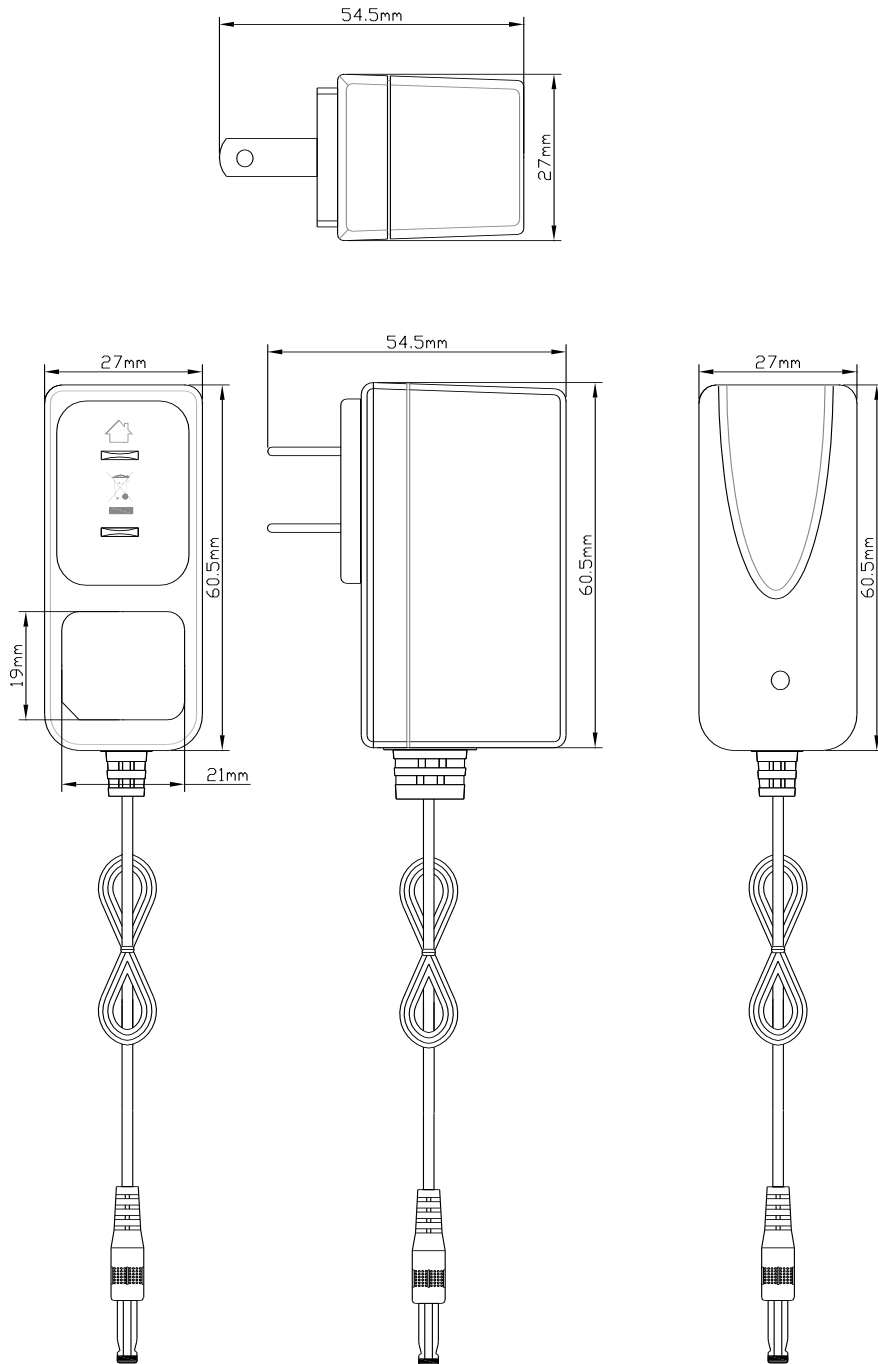

	Φ A	Φ B	C	D
DIMENSION/尺寸	5.5	2.5	10	1500
TOLERANCE/公差	±0.05	±0.05	±0.5	+20 / -20
NOTES	Cable length: 1.5m, 2464 26AWG/2C 5.5*2.5*10MM 180Degree with Fork/Kink Type and Without Filter			

NAME PLATE/铭牌

NAME PLATE/铭牌:

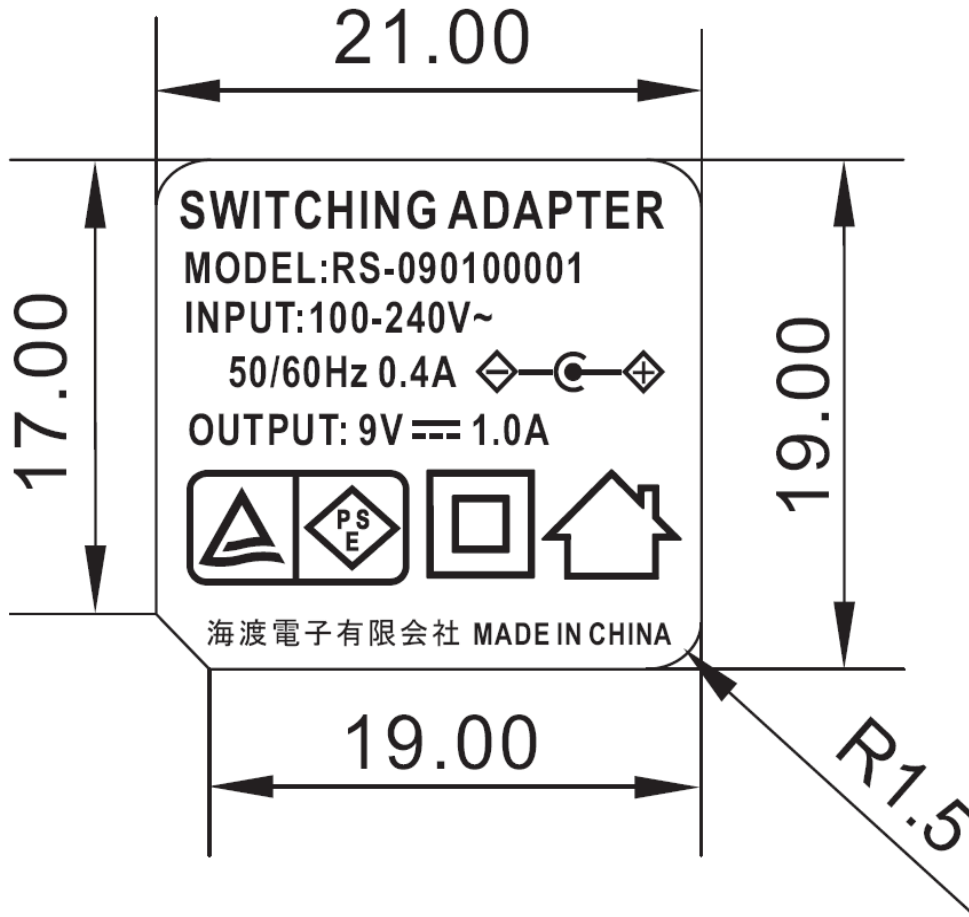

UNIT/单位: mm

TOLERANCE/公差: +0/-0.2

BACK COLOUR/底色: SILVER/银色

WORD COLOUR/字色: BLACK/黑色

* PLEASE ADVISE IF ANY COMMENT ON NAME PLATE INFORMATION. OTHERWISE, THIS INFORMATION IS REGARDED AS CUSTOMER APPROVAL AND APPLY IN PRODUCTION.

铭牌资料供客户样品认可使用,如有疑问,请于样品认可前提出,否则,资料将视作客户认可并应用于生产上.

CASING/包装

Product

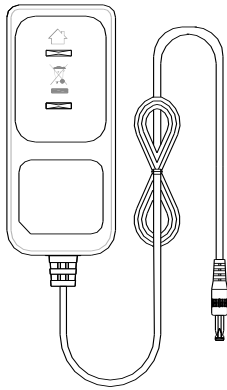

PE film bags

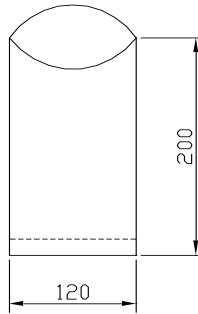

外箱 Master carton

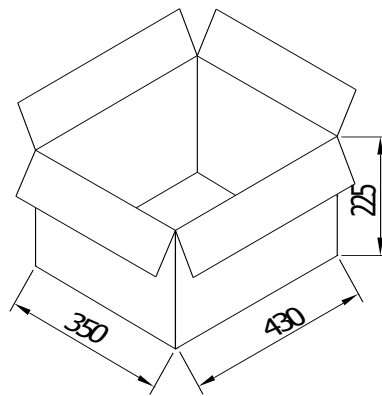

刀卡/CARTON PAPER

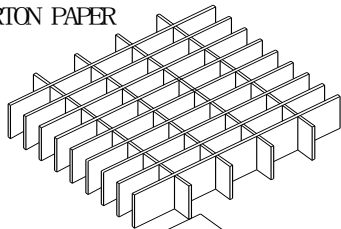

平板/PLATE PAPER

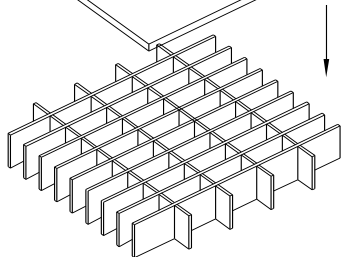
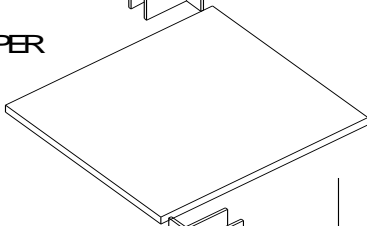

CARTON MATERIAL: K-K (5mm)

CARTON SIZE: 430*350*225mm

外箱尺寸: 430*350*225mm

Partition Board: 420*340*3 (1PCS)

Cross-Connecting Board: 420*100*3 (8PCS) A=A

Cross-Connecting Board: 330*100*3 (18PCS) A=A

QTY: 100PCS (50PCS*2)

数量: 100PCS (50PCS*2)

The tolerance of internal dimensions of the carton is +7/-0