

承认书编号: **MK-J2496**

规格承认书

SPECIFICATION FOR APPROVAL

| | |
|---|----------------------------------|
| 客户名称(CUSTOMER) | MK-J2496 |
| 客户料号 (P/N of customer) | 2665 |
| 品名 (DESCRIPTION) | JP Wall Mount type / 24VDC1000mA |
| Merryking 料号 (P/N of Merryking) | |
| Merryking 安规型号 (Model of Safety Certification) | MKE-2401000 |
| 样品数量 (Quantity of samples) | |
| 送样日期 (DATE) | |

CUSTOMER AUTHORIZED SIGNATURE/客户承认签核

| | | |
|--|--|--|
| | | |
|--|--|--|

承认记事 (REMARKS) :

Please return to us one copy of "SPECIFICATION FOR APPROVAL" with you approved signature./客户确认签字, 盖章后请回传一份承认书给我司.

深圳市钜博电子有限公司/ Shenzhen Merryking Electronics Co., Ltd.

地址: 深圳市宝安区松岗街道东方社区田洋二路南边头科技园A栋8楼

Add.: 8F, Blding B, Nanbiantou S&T Park, Tianyang 2nd Road, Oriental Community,
Songgang Street, Bao'an District, Shenzhen 518105, Guangdong, China

TEL.: +86-755-23005669 FAX: 86-755-23005900

<http://www.merryking.com>

钜博企业(香港)有限公司/Merryking Enterprises (HK)Co., Ltd.

地址: 香港九龍旺角通菜街 1A-1L 威達商業大廈 10/F1003 室

Add.: Office No.3 10/F, Witty Commercial Building, 1A-1L Tung Choi Street, Mongkok Kowloon Hong Kong

| | | |
|----|----|----|
| 拟制 | 审核 | 批准 |
| 秦云 | 秦云 | 黄勇 |

Table of contents

目錄

| | |
|--|--------------|
| Cover / 封面 ----- | P1 |
| Table of contents / 目錄 ----- | P2 |
| Electrical Performance / 電氣性能 ----- | P3-P7 |
| Product Outline / 產品外觀尺寸 ----- | P8 |
| DC Cord / 線材 ----- | P9 |
| Rating Label / 銘牌 ----- | P10 |
| Packing / 包裝圖 ----- | P11 |

UPDATE REV.

| REV | UPDATE | DATE | PRERARATOR |
|----------|--------|------------|------------|
| Original | | 2023/10/18 | 秦云 |
| | | | |
| | | | |
| | | | |
| | | | |
| | | | |

EDITION
版本

A0

ELECTRICAL PERFORMANCE / 電器性能
1. PRODUCT TYPE.产品类型:
 Wall mount type 插墙式 Interchangeable AC plug 转换头 Desktop 桌面式

2. General Description(概述)

This specification defines the input, output, performance characteristics, and environment, noise and safety requirements for **24** Watts adaptor. The adaptor is full range AC (100~240V) input and output **24V**

(本规格详细说明了 **24W** 的适配器输入、输出特性、环境、噪音和安全要求。适配器输入电压为 AC(100-240V)，输出电压为 **24V**)

3. INPUT FEATURE / 輸入特性

3.1 INPUT VOLTAGE RANGE: **90Vac** to **264Vac**. 輸入電壓範圍可以從 **90Vac** 到 **264Vac**.

3.2 RATED INPUT VOLTAGE: **100Vac** to **240Vac**. 額定輸入電壓從 **100Vac** 到 **240Vac**.

3.3 INPUT FREQUENCY RANGE: **47Hz** to **63Hz**. 輸入頻率範圍從 **47Hz** 到 **63Hz**.

3.4 INPUT CURRENT: **0.8A** Max. (I/P100-240Vac). 最大輸入電流不超過 **0.8A** (輸入條件 100-240Vac)

3.5 INRUSH CURRENT: **80A** max. at **100-240Vac** input for a cold start at 25°C. 在標準開機條件下，最大浪湧電流不超過 **80A** (輸入條件 **100-240Vac**).

3.6 EFFICIENCY:

Higher than **86.2%** at 100-240Vac input and output (25%, 50%, 75% & 100% load.).

效率高於 **86.2%** (輸入 100-240Vac · 輸出 25%, 50%, 75% & 100% 負載)

4. OUTPUT FEATURE / 輸出特性

| RATED OUTPUT / 額定輸出: 24VDC | SPEC. LIMIT / 規格限定 | | REMARK / 備註 |
|-----------------------------------|--------------------|---|--|
| | Min. value | Max. value | |
| Output regulation / 輸出電壓規格 | 22.8V DC | 25.2VDC | ≤±5% |
| Output load / 輸出負載規格 | 0.0A | 1.0A | |
| No Load Power consumption/空載功耗 | — | <input checked="" type="checkbox"/> 0.1W <input type="checkbox"/> 0.21W | Input voltage:115 & 230VAC |
| Ripple and Noise / 輸出紋波及雜訊 | — | 150mVp-p | 20MHz Bandwidth 10uF Ele. Cap. & 0.1uF Cer. Cap |
| Output Overshoot / 輸出過沖幅度 | — | 10% | |
| Line regulation / 線性調整率 | — | ±1% | |
| Load regulation / 負載調整率 | — | ±5% | |
| Turn-on delay time / 開機延遲時間 | — | 3000mS | |
| Hold up time / 關機維持時間 | 10mS | — | Input voltage:115Vac |
| | 20mS | — | Input voltage:230Vac |

5.SAFETY STANDARD / 安規標準

5.1 The green mode power supply shall be certified by the following international regulatory standards 電源應符合下列的國際標準:

| Certificate | Country/國家 | Standard / 標準 |
|--|----------------|--|
| <input checked="" type="checkbox"/> UL / cUL | USA / 美國 | <input checked="" type="checkbox"/> UL62368-1 <input type="checkbox"/> UL60950-1 <input type="checkbox"/> UL60065 <input type="checkbox"/> UL60601-1 <input type="checkbox"/> UL1310 |
| <input type="checkbox"/> ETL | USA / 美國 | <input type="checkbox"/> UL62368-1 <input type="checkbox"/> UL60950-1 <input type="checkbox"/> UL60065 <input type="checkbox"/> UL60601-1 <input type="checkbox"/> UL1310 |
| <input type="checkbox"/> GS | Germany / 德國 | <input type="checkbox"/> EN62368-1 <input type="checkbox"/> EN60950-1 <input type="checkbox"/> EN60065 <input type="checkbox"/> EN60335-1 <input type="checkbox"/> EN61347-1 <input type="checkbox"/> EN60601-1 <input type="checkbox"/> EN61558-1 &-2-16 |
| <input type="checkbox"/> CE | Europe / 歐洲 | <input type="checkbox"/> EN62368-1 <input type="checkbox"/> EN60950-1 <input type="checkbox"/> EN60065 <input type="checkbox"/> EN60335-1 <input type="checkbox"/> EN61347-1 <input type="checkbox"/> EN60601-1 <input type="checkbox"/> EN61558-1 &-2-16 |
| <input type="checkbox"/> SAA | Australia / 澳洲 | <input type="checkbox"/> AS/NZS62368-1 <input type="checkbox"/> AS/NZS60950-1 <input type="checkbox"/> AS/NZS60065 <input type="checkbox"/> AS/NZS60335-1 <input type="checkbox"/> AS/NZS61558-1 &-2-16 |
| <input checked="" type="checkbox"/> PSE | Japan / 日本 | <input checked="" type="checkbox"/> J62368-1 <input type="checkbox"/> J60950-1 <input type="checkbox"/> J60065 <input type="checkbox"/> J60335-1 <input type="checkbox"/> J61558-1&-2-16 |
| <input type="checkbox"/> S-Mark | Argentina/阿根廷 | <input type="checkbox"/> IEC62368-1 <input type="checkbox"/> IEC60950-1 <input type="checkbox"/> EC60065 <input type="checkbox"/> IEC61558-1 &-2-16 |
| <input type="checkbox"/> CCC | China/中国 | <input type="checkbox"/> GB4943 <input type="checkbox"/> GB8898 <input type="checkbox"/> GB4706.1 |
| <input type="checkbox"/> KC | Korea / 韩国 | <input type="checkbox"/> K60950-1 |
| <input type="checkbox"/> BSMI | Taiwan/台湾 | <input type="checkbox"/> CNS13438 & 14336-1 |
| <input type="checkbox"/> PSB | Singapore /新加坡 | <input type="checkbox"/> IEC62368-1 <input type="checkbox"/> IEC60950-1 <input type="checkbox"/> EC60065 <input type="checkbox"/> IEC61558-1 &-2-16 |
| <input type="checkbox"/> CB | IECEE/国际电工委员会 | <input type="checkbox"/> IEC62368-1 <input type="checkbox"/> IEC60950-1 <input type="checkbox"/> EC60065 <input type="checkbox"/> IEC61558-1 &-2-16 |

6. EMC STANDARDS / 電磁相容性標準

6.1 The power supply shall meet the following EMC standards: 本電源供應器滿足下列 EMC 標準:

| Certificate | Country/國家 | Standard / 標準 |
|---|--------------|--|
| <input checked="" type="checkbox"/> FCC | USA / 美國 | <input checked="" type="checkbox"/> FCC PART 15B <input type="checkbox"/> FCC PART 18 <input type="checkbox"/> FCC PART 15C |
| <input type="checkbox"/> ICES | Canada / 加拿大 | <input type="checkbox"/> ICES-003 <input type="checkbox"/> ICES-001 |
| <input type="checkbox"/> CE | Europe / 歐洲 | <input type="checkbox"/> EN55032 EN55024 EN61000-3-2 EN61000-3-3 <input type="checkbox"/> EN55014-1 EN55014-2 EN61000-3-2 EN61000-3-3 <input type="checkbox"/> EN55015-1 EN61547 EN61000-3-2 EN61000-3-3 |

| | | |
|---|----------------|---|
| <input type="checkbox"/> C-Tick | Australia / 澳洲 | <input type="checkbox"/> AS/NZS CISPR22 <input type="checkbox"/> AS/NZS CISPR14.1 <input type="checkbox"/> AS/NZS CISPR15 <input type="checkbox"/> AS/NZS CISPR13 |
| <input type="checkbox"/> KCC | Korea / 韩国 | <input type="checkbox"/> K32/K35 <input type="checkbox"/> K14 <input type="checkbox"/> K11 <input type="checkbox"/> K15 |
| <input checked="" type="checkbox"/> PSE | Japan / 日本 | <input checked="" type="checkbox"/> J55032 <input type="checkbox"/> J55014-1 <input type="checkbox"/> J55013 <input type="checkbox"/> J55015 |
| <input type="checkbox"/> CCC | China/中国 | <input type="checkbox"/> GB9254 <input type="checkbox"/> GB4343.1 <input type="checkbox"/> GB17743 <input type="checkbox"/> GB13837 <input type="checkbox"/> GB17625.1 |

6.2 EMS Standards/EMS 标准

EN 61000-4-2,electrostatic discharge(ESD) requirement/静电抗扰度要求

| Discharge characteristic/静电规格 | Test level/测试条件 | Test criteria/测试标准 |
|-------------------------------|-----------------|--------------------|
| Air discharge/空气放电 | +/-8KV | B |
| Contact discharge/接触放电 | +/-4KV | B |

7. ELECTRIC WITHSTANDING STRENGTH(HI-POT) / 絕緣介電強度 (耐壓)

Primary to Secondary **AC3000V/10mA** , **1** minute for type test. **3** second for production.一次側對二次側: **AC3000V/10mA** 標準測試 **1**分鐘, 量產測試 **3**秒鐘.

8. PROTECTION FEATURE / 保護特性

8.1 OVER—CURRENT PROTECTION / 過電流保護:

The green mode power supply shall be hiccupped when any output operating in overload condition(set@ Max load **110~200 %**) under any line condition for an indefinite period of time. The power supply shall be self—recovery when the fault condition is removed.在任何時候任何輸入條件, 當輸出操作在超載條件最大電源的 (**110~200 %**) 時, 電源供應器將進入打嗝模式, 當故障被移走後, 電源要能自動恢復到正常。

8.2 SHORT CIRCUIT PROTECTION / 輸出短路保護:

The power supply shall be hiccupped and no damage shall occur when any output operating in a short circuit condition under any line condition for an indefinite period of time. The power supply shall be self—recovery when the fault condition is removed.在任何時候, 任何輸入條件下, 當輸出操作在短路情況下, 電源供應器將進入打嗝模式, 當故障消失後, 電源要能自動恢復正常。

9. ENVIRONMENTAL CONDITIONS / 環境條件

9.1 OPERATING / 操作條件:

The power supply shall be capable of operating continuously in any mode without performance deterioration in the following environmental conditions.在下列環境條件下, 電源供應器要能夠連續操作在各種模式, 且不能造成性能的退化。

9.1.1 Ambient Temperature: 0°C~40°C 環境測度: 0°C~40°C

9.1.2 Relative Humidity: 10%~90% 相對濕度: 10%~90%

9.1.3 Vibration: 1.0mm, 10—25Hz, 15 minutes per cycle for each axis (X, Y, Z)

9.1.4 Cooling: The power supply will operate with convection cooling .Blocking of vents must not cause damage to The power supply. 電源供應器將操作在對流冷卻的環境下，即使將通風口阻塞電源也不允許有任何損傷發生。

9.2 NON—OPERATING / 非操作條件:

The power supply shall be capable of withstanding the following environmental conditions extended periods of time, without sustaining electrical or mechanical damage and subsequent operational deficiencies: 電源供應器要能夠長期的經受下列的環境條件，且不允許有電氣級機械方面的損傷和併發的操作的缺失。

9.2.1 Ambient Temperature: $-20^{\circ}\text{C} \sim 60^{\circ}\text{C}$ 環境溫度: $-20^{\circ}\text{C} \sim 60^{\circ}\text{C}$

9.2.2 Relative Humidity: 10%~90% 相對濕度: 10%~90%

9.2.3 Vibration and Shock / 振動和衝擊

The power supply shall be designed to withstand normal transportation vibration per MIL-STD-810D, method 514 and procedures X, as it s mounted in the chassis assembly and packed for shipping. 電源供應器裝配及出貨的包裝設計，均要能承受正常運輸的振動，並符合 MIL—STD—810D 方法 514 和程式 X。

10. Energy Saving (Level VI / Level 6) 符合節能 6 級標準，測試標準如下:

- 10.1 US DOE: Office of Energy Efficiency and Renewable Energy 10 CFR Parts 429 and 430
- 10.2 CEC: Appliance Efficiency Regulations (California Code of Regulations, Title 20, Sections 1601 through 1608) dated July 2015
- 10.3 NRCAN: Amendment 11 to the Energy Efficiency Regulations for External Power Supplies, published on October 12, 2011 in the Canada Gazette, Part II
- 10.4 Other (Specify): International Efficiency Marking Protocol for External Power Supplies - Level VI
- 10.5 Other (Specify): Australian (GEMS) and New Zealand : AS/NZS4665.1-2005+A1:2009; AS/NZS4665.2-2005+A1:2009
- 10.6 Other (Specify): EU Directive for Energy-related Products ErP 2009/125/EC and Implementing Measure (IM) no. EC278/2009 for External Power Supply
- 10.7 Other (Specify): Code of Conduct on Energy Efficiency of External Power Supplies Version 5

11. RELIABILITY AND QUALITY CONTROL / 可靠性及品質控制

11.1 MTBF/故障率 The predicted and demonstrated MTBF must be greater than 50K hours at 25°C .

11.2 BURN-IN / 燒機 The power supply shall undergo a minimum of **4** hours Burn-In test under full load at **$40^{\circ}\text{C} \sim \pm 5^{\circ}\text{C}$** 電源應在 **$40^{\circ}\text{C} \sim \pm 5^{\circ}\text{C}$** 和滿載條件下烘烤 **4** 小時。

11.3 COMPONENT DERATING / 元件溫度要求 Semiconductor junction temperatures shall not exceed the manufacturer's maximum thermal rating. 半導體結溫不允許超過其製造商要求的最大溫度值。

11.4 QUALITY GUARANTEE/品質保證: 2 years warranty. 2年品質保固。

12.WEIGHT / 重量 The weight of the power supply shall be about 134g. 電源的重量大約為 134g.

13.MECHANICAL REQUIREMENT / 結構參數 The power supply size: L74*W34*H52mm. 外型尺寸: L74*W34*H52mm.

14.INSULATION RESISTANCE / 絕緣阻抗 Input to output: 50M OHM(500VDC) 輸入對輸出 50兆 歐姆 (500VDC)

15.LEAKAGE CURRENT / 漏電流 The leakage current shall be less than 0.25mA for class II when power supply is operated maximum input voltage and maximum load. 當電源供應器操作在最大輸入及最大負載情況下, 其漏電流應小於 0.25mA, 滿足 class II 等級。

16.MAJOR MEASURE EQUIPMENT / 主要測量設備

A. AC SOURCE / 交流輸入電源: AFC-500W

B. POWER METER / 電源功率計: CHROMA 2100

C. ELECTRONIC LOAD / 電子負載: PRODIGIT 3310C

D. OSCILLOSCOPE / 存儲示波器: TDS-2012B

E. DIGITAL MULTIMETER / 數字式萬用表: Fluke 4.5

F. DC POWER / 直流輸入電源: WYK-6030

G. HI-POT TESTER / 耐壓測試儀: LANKE ELECTRONICS 7112

H. INSULATION RASISTANCE TESTER / 絕緣電阻表: YD2681A

EDITION
版本

A0

PRODUCT OUTLINE DIMENSION / 產品外觀尺寸

Unit / 單位:mm

Tolerance / 公差:±1

Color/顏色: 黑色/Black

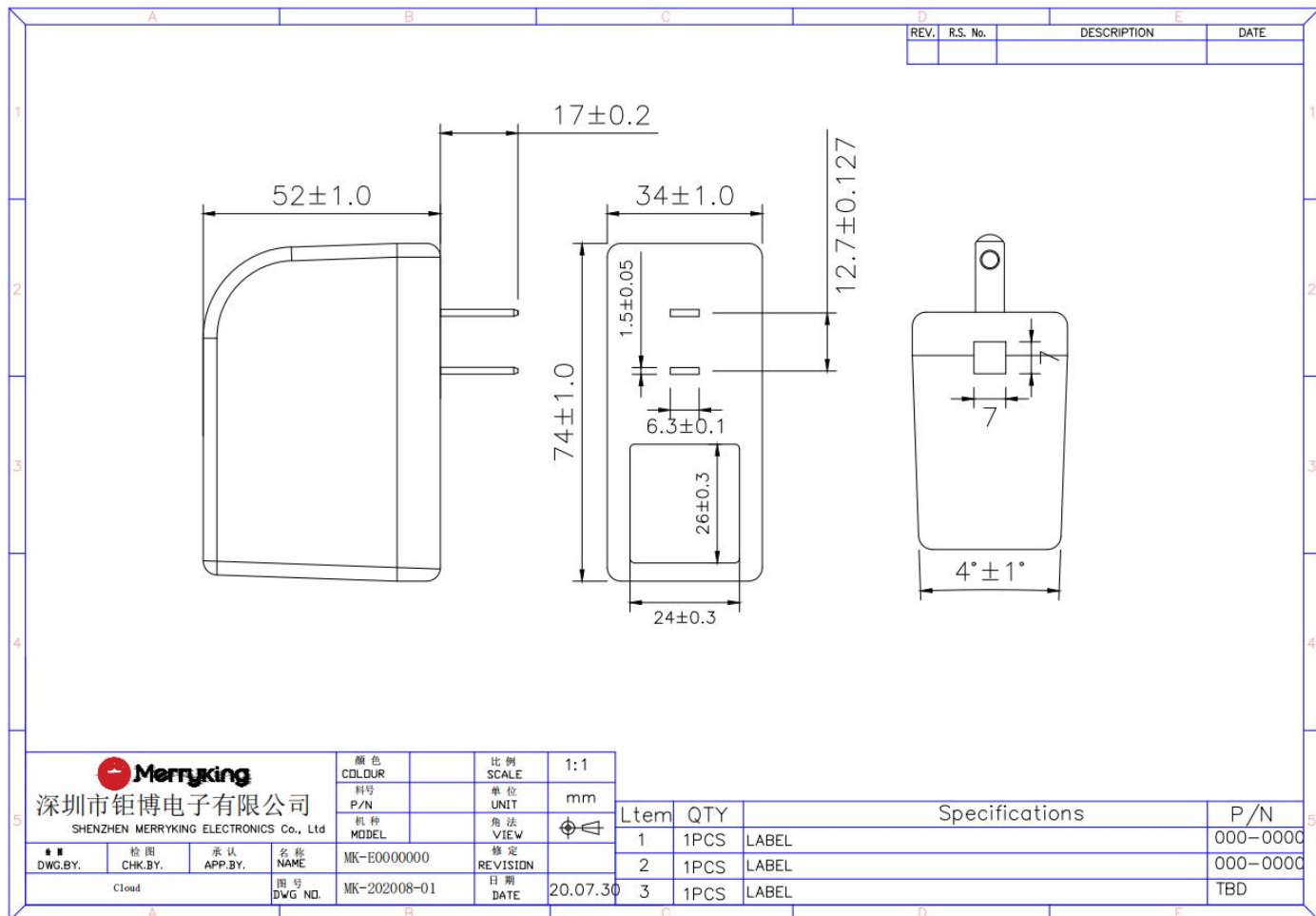
 EDITION
 版本

A0

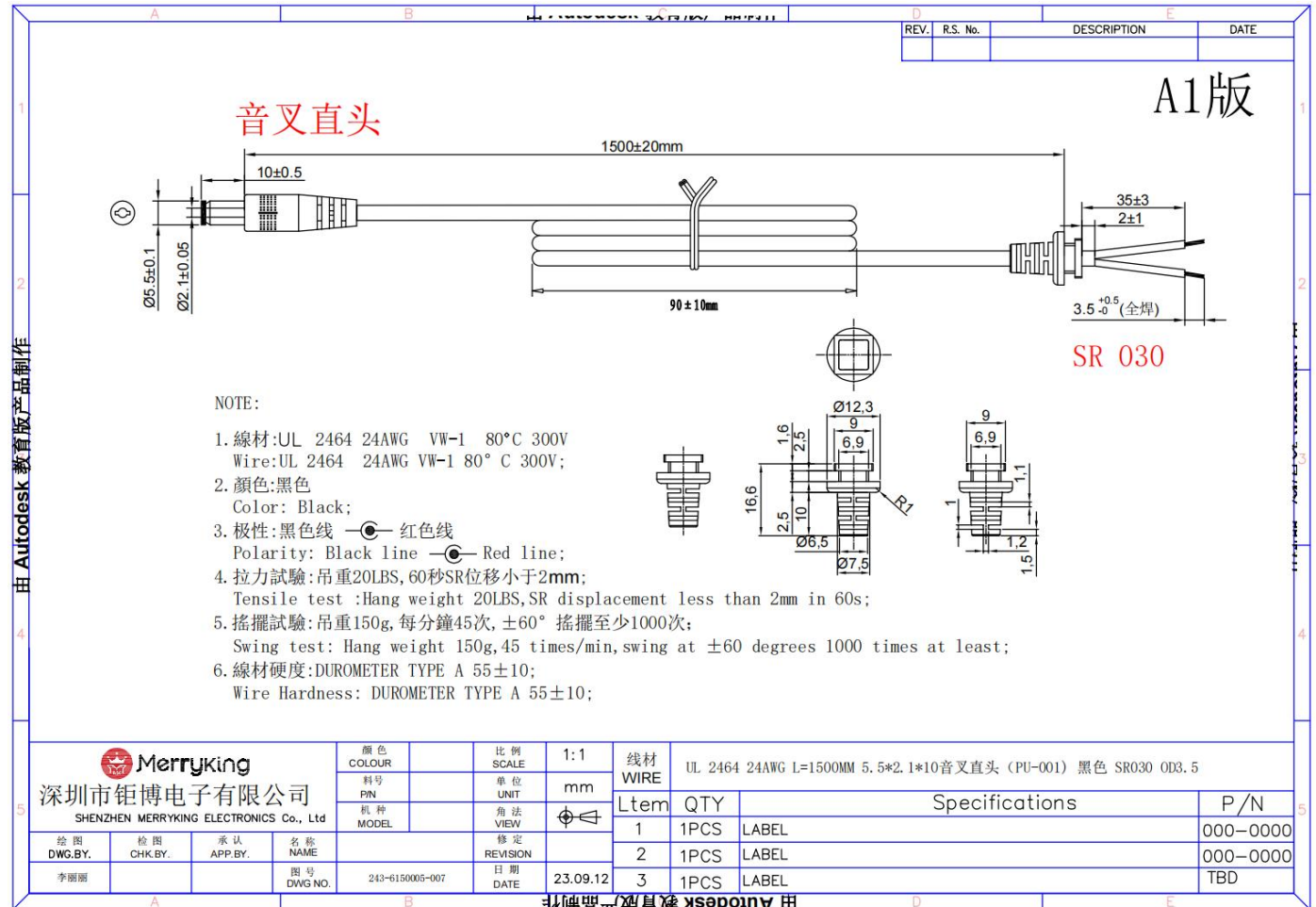
DC CORD / 線材
Unit / 單位:mm
Tolerance / 公差:
Color/顏色: 黑色/Black

SEDITION
版本
A0

RATING LABEL / 銘牌

Unit / 單位:mm

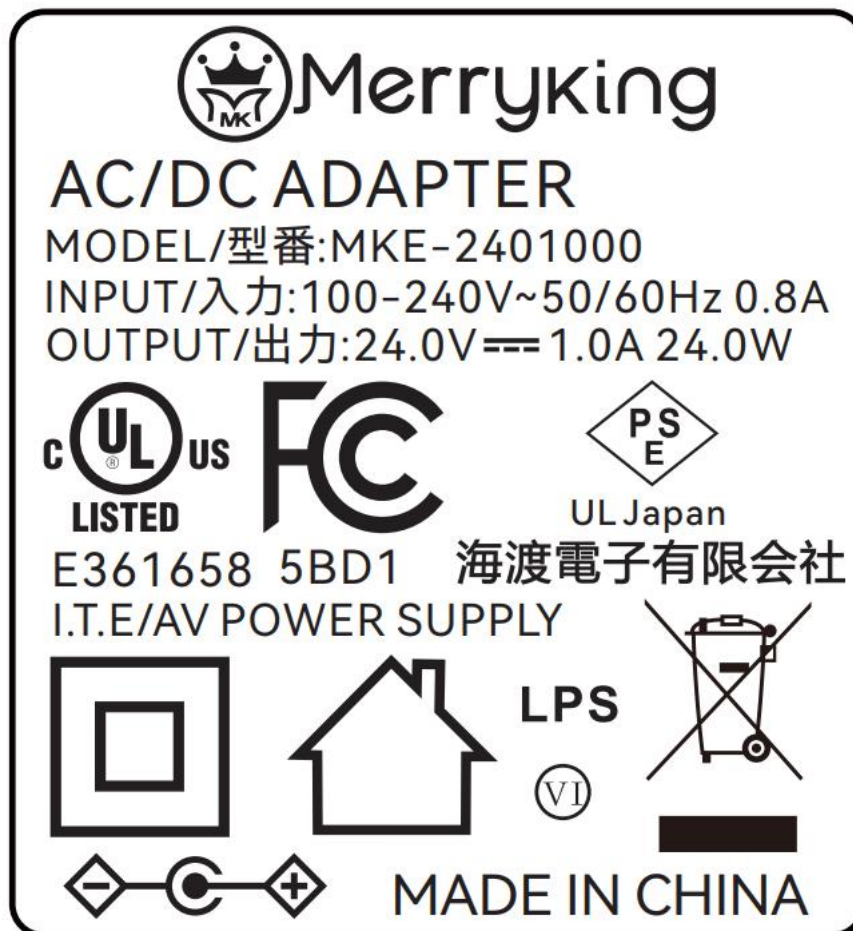
Tolerance / 公差:+0/-0.2mm



鐳

雕

注:

1. 黑底灰字 - Gray text on black ground.
2. 鐳雕清晰, 耐擦拭 - Laser printing, wipe resistance.
3. 符合環保要求 - Compliance to RoHS.

EDITION
 版本

A0

PACKING / 包裝

| REV. | R.S. No. | DESCRIPTION | DATE |
|------|----------|-------------|------|
| | | | |

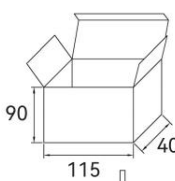

NOTE:

- 1.尺寸為內部尺寸
- 2.材質: 300磅紙板
- 3.顏色: 白色

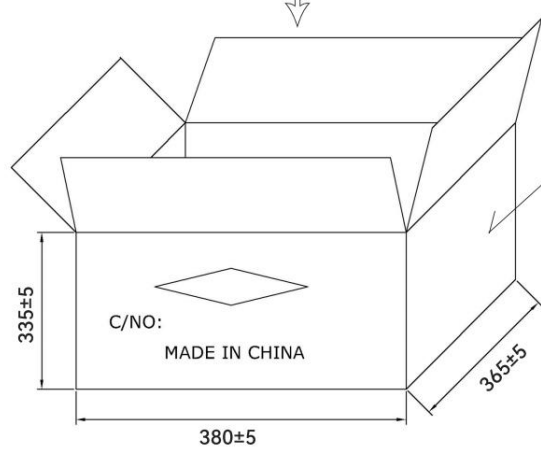





P.O.:
P/N:
QTY: PCS
N.W.: KGS
G.W.: KGS



平卡(材質B3C) 360*345*3mm

NOTE:

- 1.96PCS/箱
- 2.PK箱標示尺寸為內部尺寸
- 3.PK箱印前後相同,左右相同,印刷顏色為黑色
- 4.上,下放平卡

| | | | | | |
|---|---------------|---------------|---------------|----------------|---|
|  Merryking 深圳市钜博电子有限公司 SHENZHEN MERRYKING ELECTRONICS Co., Ltd | | 顏色 COLOUR | 黑色 | 比例 SCALE | 1:1 |
| 繪圖 DWG.BY. | 檢閱 CHK.BY. | 承認 APP.BY. | 料號 P/N | 單位 UNIT | mm |
| | | | 機種 MODEL | 角法 VIEW |  |
| | | | 名稱 NAME | 修定 REVISION | |
| | | | 圖號 DWG NO. | 日期 DATE | 20.07.28 |
| | | | | | |

EDITION
版本
A0