

承认书编号: **MK-J2496**

规格承认书

SPECIFICATION FOR APPROVAL

客户名称(CUSTOMER)	MK-J2496
客户料号 (P/N of customer)	N/A
品名 (DESCRIPTION)	Desktop / 24VDC 6250mA
Merryking 料号 (P/N of Merryking)	
Merryking 安规型号 (Model of Safety Certification)	MKJ-2400625C8
样品数量 (Quantity of samples)	
送样日期 (DATE)	

CUSTOMER AUTHORIZED SIGNATURE/客户承认签核

--	--	--

承认记事 (REMARKS) :

Please return to us one copy of "SPECIFICATION FOR APPROVAL" with you approved signature./客户确认签字, 盖章后请回传一份承认书给我司.

深圳市钜博电子有限公司/ Shenzhen Merryking Electronics Co., Ltd.

地址: 深圳市宝安区松岗街道东方社区田洋二路南边头科技园A栋8楼

Add.: 8F, Blding A, Nanbiantou S&T Park, Tianyang 2nd Road, Oriental Community,
Songgang Street, Bao'an District, Shenzhen 518105, Guangdong, China

TEL.: +86-755-23005669 FAX: 86-755-23005900

<http://www.merryking.com>

钜博企业(香港)有限公司/Merryking Enterprises (HK)Co., Ltd.

地址: 香港九龍旺角通菜街 1A-1L 威達商業大廈 10/F1003 室

Add.: Office No.3 10/F, Witty Commercial Building, 1A-1L Tung Choi Street, Mongkok Kowloon Hong Kong

拟制	审核	批准
莫似钰	李丽丽	黄勇



Table of contents

目錄

Cover / 封面 ----- P1

Table of contents / 目錄 ----- P2

Electrical Performance / 電氣性能 ----- P3-P8

Product Outline / 產品外觀尺寸 ----- P9

DC Cord / 線材 ----- P10

Rating Label / 銘牌 ----- P11

Packing / 包裝圖 ----- P12

UPDATE REV.

REV	UPDATE	DATE	PRERARATOR
Original		2023/07/04	莫似钰

EDITION
版本

A0



ELECTRICAL PERFORMANCE / 電器性能

1. PRODUCT TYPE.产品类型:

Wall mount type 插牆式 Interchangeable AC plug 转换头 Desktop 桌面式

2. General Description(概述)

This specification defines the input, output, performance characteristics, and environment, noise and safety requirements for **150** Watts adaptor. The adaptor is full range AC (100~240V) input and output **24V**

(本规格详细说明了 **150W** 的适配器输入、输出特性、环境、噪音和安全要求。适配器输入电压为 AC(100-240V)，输出电压为 **24V**)

3. INPUT FEATURE / 輸入特性

3.1 INPUT VOLTAGE RANGE: **90Vac** to **264Vac**. 輸入電壓範圍可以從 **90Vac** 到 **264Vac**.

3.2 RATED INPUT VOLTAGE: **100Vac** to **240Vac**. 額定輸入電壓從 **100Vac** 到 **240Vac**.

3.3 INPUT FREQUENCY RANGE: **47Hz** to **63Hz**. 輸入頻率範圍從 **47Hz** 到 **63Hz**.

3.4 INPUT CURRENT: **2.5A** Max. (I/P100-240Vac). 最大輸入電流不超過 **2.5A** (輸入條件 100-240Vac)

3.5 INRUSH CURRENT: **100A** max. at **100-240Vac** input for a cold start at 25°C. 在標準開機條件下，最大浪湧電流不超過 **100A** (輸入條件 **100-240Vac**).

3.6 EFFICIENCY:

Higher than **87%** at 100-240Vac input and output (25%, 50%, 75% & 100% load).

效率高於 **87%** (輸入 100-240Vac · 輸出 25%, 50%, 75% & 100% 負載)

4. OUTPUT FEATURE / 輸出特性

RATED OUTPUT / 額定輸出: 24VDC	SPEC. LIMIT / 規格限定		REMARK / 備註
	Min. value	Max. value	
Output regulation / 輸出電壓規格	22.8VDC	25.2VDC	≤ ±5%
Output load / 輸出負載規格	0.0A	6.25A	
No Load Power consumption/空載功耗	—	<input type="checkbox"/> 0.1W <input checked="" type="checkbox"/> 0.21W	Input voltage:115 & 230VAC
Ripple and Noise / 輸出紋波及雜訊	—	200mVp-p	20MHz Bandwidth 10uF Ele. Cap. & 0.1uF Cer. Cap
Output Overshoot / 輸出過沖幅度	—	10%	
Line regulation / 線性調整率	—	±1%	
Load regulation / 負載調整率	—	±5%	
Turn-on delay time / 開機延遲時間	—	3000mS	
Hold up time / 關機維持時間	10mS	—	Input voltage:115Vac
	20mS	—	Input voltage:230Vac
Test condition / 測試條件	<input type="checkbox"/> USBoutput/USB 輸出 <input checked="" type="checkbox"/> Belt wire product/帶線產品		Testing wire/测试线: 1.0M 22AWG



5. SAFETY STANDARD / 安規標準

5.1 The green mode power supply shall be certified by the following international regulatory standards 電源應符合下列的國際標準:

Certificate	Regions/國家和地區	Standard / 標準
<input checked="" type="checkbox"/> UL / cUL	USA / 美國	<input checked="" type="checkbox"/> UL62368-1 <input type="checkbox"/> UL60950-1 <input type="checkbox"/> UL60065 <input type="checkbox"/> UL60601-1 <input type="checkbox"/> UL1310
<input type="checkbox"/> ETL	USA / 美國	<input type="checkbox"/> UL62368-1 <input type="checkbox"/> UL60950-1 <input type="checkbox"/> UL60065 <input type="checkbox"/> UL60601-1 <input type="checkbox"/> UL1310
<input checked="" type="checkbox"/> GS	Germany / 德國	<input checked="" type="checkbox"/> EN62368-1 <input type="checkbox"/> EN60950-1 <input type="checkbox"/> EN60065 <input type="checkbox"/> EN60335-1 <input type="checkbox"/> EN61347-1 <input type="checkbox"/> EN60601-1 <input type="checkbox"/> EN61558-1 &-2-16
<input checked="" type="checkbox"/> CE	Europe / 歐洲	<input checked="" type="checkbox"/> EN62368-1 <input type="checkbox"/> EN60950-1 <input type="checkbox"/> EN60065 <input type="checkbox"/> EN60335-1 <input type="checkbox"/> EN61347-1 <input type="checkbox"/> EN60601-1 <input type="checkbox"/> EN61558-1 &-2-16
<input checked="" type="checkbox"/> UKCA	UK / 英国	<input checked="" type="checkbox"/> BS EN62368-1 <input type="checkbox"/> BS EN60950-1 <input type="checkbox"/> BS EN60065 <input type="checkbox"/> BS EN60335-1 <input type="checkbox"/> BS EN61347-1 <input type="checkbox"/> BS EN60601-1 <input type="checkbox"/> BS EN61558-1 &-2-16
<input checked="" type="checkbox"/> SAA	Australia / 澳洲	<input checked="" type="checkbox"/> AS/NZS62368-1 <input type="checkbox"/> AS/NZS60950-1 <input type="checkbox"/> AS/NZS60065 <input type="checkbox"/> AS/NZS60335-1 <input type="checkbox"/> AS/NZS61558-1 &-2-16
<input checked="" type="checkbox"/> PSE	Japan / 日本	<input checked="" type="checkbox"/> J62368-1 <input type="checkbox"/> J60950-1 <input type="checkbox"/> J60065 <input type="checkbox"/> J60335-1 <input type="checkbox"/> J61558-1&-2-16
<input type="checkbox"/> S-Mark	Argentina/阿根廷	<input type="checkbox"/> IEC62368-1 <input type="checkbox"/> IEC60950-1 <input type="checkbox"/> EC60065 <input type="checkbox"/> IEC61558-1 &-2-16
<input type="checkbox"/> CCC	China/中国	<input type="checkbox"/> GB4943 <input type="checkbox"/> GB8898 <input type="checkbox"/> GB4706.1
<input type="checkbox"/> KC	Korea / 韩国	<input type="checkbox"/> K60950-1
<input type="checkbox"/> BSMI	Taiwan/台湾	<input type="checkbox"/> CNS13438 & 14336-1
<input type="checkbox"/> PSB	Singapore /新加坡	<input type="checkbox"/> IEC62368-1 <input type="checkbox"/> IEC60950-1 <input type="checkbox"/> EC60065 <input type="checkbox"/> IEC61558-1 &-2-16
<input type="checkbox"/> CB	IECEE/国际电工委员会	<input type="checkbox"/> IEC62368-1 <input type="checkbox"/> IEC60950-1 <input type="checkbox"/> EC60065 <input type="checkbox"/> IEC61558-1 &-2-16



6. EMC STANDARDS / 電磁相容性標準

6.1 The power supply shall meet the following EMC standards: 本電源供應器滿足下列 EMC 標準:

Certificate	Regions/國家和地區	Standard / 標準
<input checked="" type="checkbox"/> FCC	USA / 美國	<input checked="" type="checkbox"/> FCC PART 15B <input type="checkbox"/> FCC PART 18 <input type="checkbox"/> FCC PART 15C
<input type="checkbox"/> ICES	Canada / 加拿大	<input type="checkbox"/> ICES-003 <input type="checkbox"/> ICES-001
<input checked="" type="checkbox"/> CE	Europe / 歐洲	<input checked="" type="checkbox"/> EN55032 EN55024 EN61000-3-2 EN61000-3-3 <input type="checkbox"/> EN55014-1 EN55014-2 EN61000-3-2 EN61000-3-3 <input type="checkbox"/> EN55015-1 EN61547 EN61000-3-2 EN61000-3-3 <input type="checkbox"/> EN60601-1-2:2015+A1-2021 IEC60601-1-2:2014+A1:2020
<input checked="" type="checkbox"/> UKCA	UK / 英国	<input checked="" type="checkbox"/> BS EN55032 BS EN55024 BS EN61000-3-2 BS EN61000-3-3 <input type="checkbox"/> BS EN55014-1 BS EN55014-2 BS EN61000-3-2 BS EN61000-3-3 <input type="checkbox"/> BS EN55015-1 BS EN61547 BS EN61000-3-2 BS EN61000-3-3
<input checked="" type="checkbox"/> C-Tick	Australia / 澳洲	<input checked="" type="checkbox"/> AS/NZS CISPR22 <input type="checkbox"/> AS/NZS CISPR14.1 <input type="checkbox"/> AS/NZS CISPR15 <input type="checkbox"/> AS/NZS CISPR13
<input type="checkbox"/> KCC	Korea / 韩国	<input type="checkbox"/> K32/K35 <input type="checkbox"/> K14 <input type="checkbox"/> K11 <input type="checkbox"/> K15
<input checked="" type="checkbox"/> PSE	Japan / 日本	<input checked="" type="checkbox"/> J55032 <input type="checkbox"/> J55014-1 <input type="checkbox"/> J55013 <input type="checkbox"/> J55015
<input type="checkbox"/> CCC	China/中国	<input type="checkbox"/> GB9254 <input type="checkbox"/> GB4343.1 <input type="checkbox"/> GB17743 <input type="checkbox"/> GB13837 <input type="checkbox"/> GB17625.1

6.2 EMS Standards/EMS 标准

EN 61000-4-2,electrostatic discharge(ESD) requirement/静电抗扰度要求

Discharge characteristic/静电规格	Test level/测试条件	Test criteria/测试标准
Air discharge/空气放电	+/-8KV	B
Contact discharge/接触放电	+/-4KV	B

7. ELECTRIC WITHSTANDING STRENGTH(HI-POT) / 絕緣介電強度 (耐壓)

Primary to Secondary **AC3000V/10mA** , **1** minute for type test. **3** second for production. 一次側對二次側: **AC3000V/10mA** 標準測試 **1**分鐘, 量產測試 **3**秒鐘.



8. PROTECTION FEATURE / 保護特性

8.1 OVER—CURRENT PROTECTION / 過電流保護：

The green mode power supply shall be hiccupped when any output operating in overload condition(set@ Max load **110~200%**) under any line condition for an indefinite period of time. The power supply shall be self—recovery when the fault condition is removed.在任何時候任何輸入條件，當輸出操作在超載條件最大電源的（**110~200%**）時，電源供應器將進入打嗝模式，當故障被移走後，電源要能自動恢復到正常。

8.2 SHORT CIRCUIT PROTECTION / 輸出短路保護：

The power supply shall be hiccupped and no damage shall occur when any output operating in a short circuit condition under any line condition for an indefinite period of time. The power supply shall be self—recovery when the fault condition is removed.在任何時候，任何輸入條件下，當輸出操作在短路情況下，電源供應器將進入打嗝模式，當故障消失後，電源要能自動恢復正常。

9. ENVIRONMENTAL CONDITIONS / 環境條件

9.1 OPERATING / 操作條件：

The power supply shall be capable of operating continuously in any mode without performance deterioration in the following environmental conditions.在下列環境條件下，電源供應器要能夠連續操作在各種模式，且不能造成性能的退化。

9.1.1 Ambient Temperature: $-10^{\circ}\text{C} \sim 40^{\circ}\text{C}$ 環境溫度： $-10^{\circ}\text{C} \sim 40^{\circ}\text{C}$

9.1.2 Relative Humidity: 10%~90% 相對濕度：10%~90%

9.1.3 Vibration: 1.0mm, 10—25Hz, 15 minutes per cycle for each axis (X, Y, Z)

9.1.4 Cooling: The power supply will operate with convection cooling .Blocking of vents must not cause damage to The power supply. 電源供應器將操作在對流冷卻的環境下，即使將通風口阻塞電源也不允許有任何損傷發生。

9.2 NON—OPERATING / 非操作條件：

The power supply shall be capable of withstanding the following environmental conditions extended periods of time, without sustaining electrical or mechanical damage and subsequent operational deficiencies: 電源供應器要能夠長期的經受下列的環境條件，且不允許有電氣級機械方面的損傷和併發的操作的缺失。

9.2.1 Ambient Temperature: $-20^{\circ}\text{C} \sim 60^{\circ}\text{C}$ 環境溫度： $-20^{\circ}\text{C} \sim 60^{\circ}\text{C}$

9.2.2 Relative Humidity: 10%~90% 相對濕度：10%~90%

9.2.3 Vibration and Shock / 振動和衝擊

The power supply shall be designed to withstand normal transportation vibration per MIL-STD-810D, method 514 and procedures X, as it s mounted in the chassis assembly and



packed for shipping. 電源供應器裝配及出貨的包裝設計，均要能承受正常運輸的振動，並符合 MIL-STD-810D 方法 514 和程式 X。

10. Energy Saving (Level VI / Level 6) 符合節能 6 級標準，測試標準如下：

- 10.1 US DOE: Office of Energy Efficiency and Renewable Energy 10 CFR Parts 429 and 430
- 10.2 CEC: Appliance Efficiency Regulations (California Code of Regulations, Title 20, Sections 1601 through 1608) dated July 2015
- 10.3 NRCAN: Amendment 11 to the Energy Efficiency Regulations for External Power Supplies, published on October 12, 2011 in the Canada Gazette, Part II
- 10.4 Other (Specify): International Efficiency Marking Protocol for External Power Supplies - Level VI
- 10.5 Other (Specify): Australian (GEMS) and New Zealand : AS/NZS4665.1-2005+A1:2009; AS/NZS4665.2-2005+A1:2009
- 10.6 Other Erp(Specify): EU Directive for Energy-related Products EC Regulation 2019/1782:2019-11-14 & EN50563:2011/A1:2013 in excerpt
- 10.7 Other (Specify): Code of Conduct on Energy Efficiency of External Power Supplies Version 5

11. RELIABILITY AND QUALITY CONTROL / 可靠性及品質控制

11.1 MTBF/故障率 The predicted and demonstrated MTBF must be greater than 50K hours at 25° C. 11.2

BURN-IN / 燒機 The power supply shall undergo a minimum of **4** hours Burn-In test under full load at **40°C~±5°C** 電源應在 **40°C~±5°C** 和滿載條件下烘烤 **4** 小時。

11.3 COMPONENT DERATING / 元件溫度要求 Semiconductor junction temperatures shall not exceed the manufacturer's maximum thermal rating. 半導體結溫不允許超過其製造商要求的最大溫度值。

11.4 QUALITY GUARANTEE/品質保證: **2 years** warranty. **2**年品質保固。

12. WEIGHT / 重量 The weight of the power supply shall be about **482g** 電源的重量大約為 **482g**

13. MECHANICAL REQUIREMENT / 結構參數 The power supply size: **L152*W62.6*H35mm**. 外型尺寸: **L152*W62.6*H35mm**.

14. INSULATION RESISTANCE / 絕緣阻抗 Input to output: **50M** OHM(500VDC) 輸入對輸出 **50** 兆歐姆 (500VDC)

15. LEAKAGE CURRENT / 漏電流 The leakage current shall be less than **0.5mA** for **class II** when power supply is operated maximum input voltage and maximum load. 當電源供應器操作在最大輸入及最大負載情況下，其漏電流應小於 **0.5mA**, 滿足 **class II** 等級。



16. MAJOR MEASURE EQUIPMENT / 主要測量設備

A. AC SOURCE / 交流輸入電源: CHROMA 61504

B. POWER METER / 電源功率計: ZLG PA310

C. ELECTRONIC LOAD / 電子負載: JARTUL JT6112

D. OSCILLOSCOPE / 存儲示波器: TEKTRONIX MDO3022

E. DIGITAL MULTIMETER / 數字式萬用表: Fluke 15B+

F. DC POWER / 直流輸入電源: LONGWEI LW-K305D

G. HI-POT TESTER / 耐壓測試儀: EXTECH ELECTRONICS 7440

H. INSULATION RESISTANCE TESTER / 絕緣電阻表: EXTECH ELECTRONICS 7440

EDITION
版本

A0



PRODUCT OUTLINE DIMENSION / 產品外觀尺寸

Unit / 單位:mm

Tolerance / 公差:±1

Color/顏色: 黑色/Black

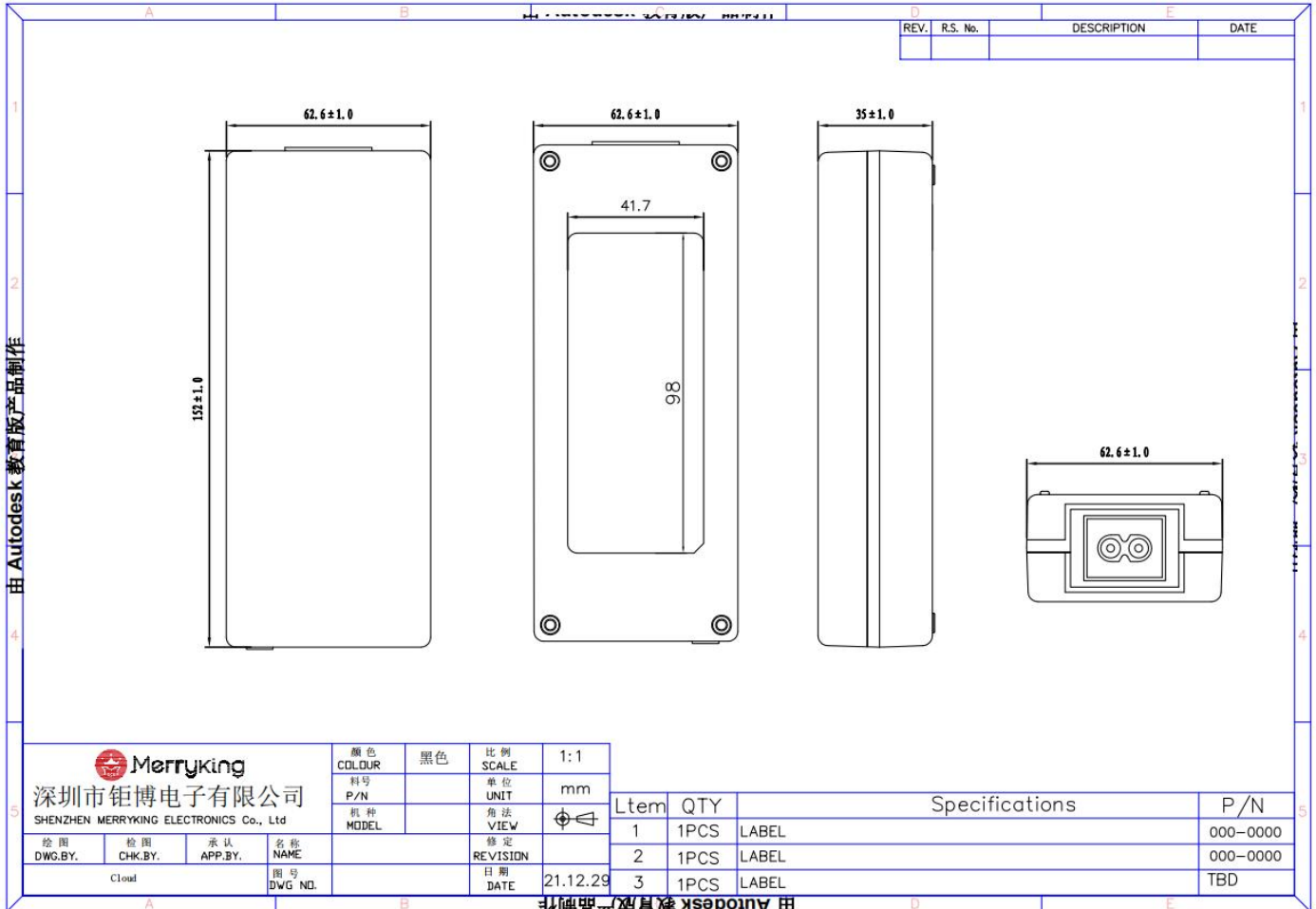

EDITION
版本

A0

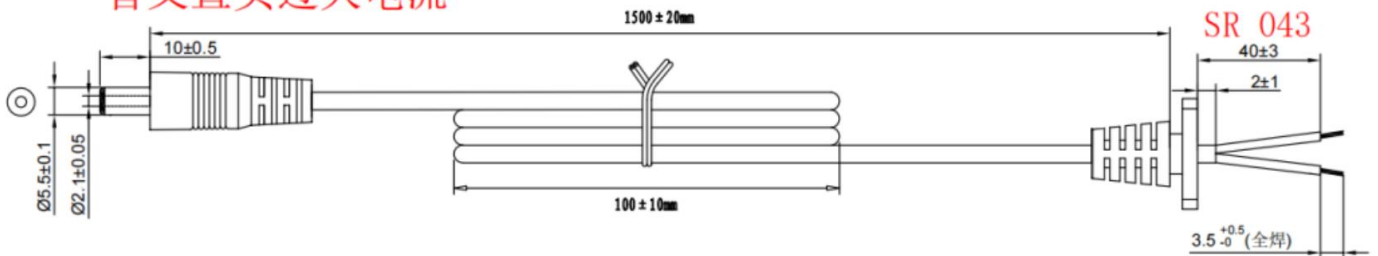
DC CORD / 線材
Unit / 單位:mm
Tolerance / 公差:
Color/顏色: 黑色/Black
音叉直頭过大电流

NOTE:

1. 線材:UL 2464 18AWG VW-1 80°C 300V
Wire: UL 2464 18AWG VW-1 80° C 300V;
2. 顏色:黑色
Color:Black ;
3. 极性:黑色线 —●— 红色线
Polarity: Black line —●— Red line;
4. 拉力試驗:吊重20LBS, 60秒SR位移小于2mm;
Tensile test :Hang weight 20LBS, SR displacement less than 2mm in 60s;
5. 搖擺試驗:吊重250g, 每分鐘45次, ±60° 搖擺至少1000次;
Swing test: Hang weight 250g, 45 times/min, swing at ±60 degrees 1000 times at least;
6. 線材硬度:DUROMETER TYPE A 55±10;
Wire Hardness: DUROMETER TYPE A 55±10;















SEDITION
 版本

A0

RATING LABEL / 銘牌

Unit / 單位:mm

Tolerance / 公差:+0/-0.2mm

AC/DC ADAPTER MODEL/型番: MKJ-2400625C8 INPUT/入力: 100-240V~50/60Hz 2.5A OUTPUT/出力: 24.0V \equiv 6.25A 150.0W		 Merryking					
							
							
E361658 5BD1 I.T.E/AV POWER SUPPLY				海渡電子有限会社			
Shenzhen Merryking Electronics Co., Ltd.				MADE IN CHINA			

鐳 雕

注:

1. 鐳雕文字-Radium carved characters.
2. 鐳雕清晰, 耐擦拭- laser printing, wipe resistance
3. 符合環保要求-Compliance to RoHS.
4. YYMM 表示週期-YYMM means Date Code
 MM 表示月(01-12) -MM means Month (like 01-12)
 YY 表示年(如 20)- YY means Year (like 20)

EDITION
 版本

A0

PACKING / 包裝

REV.	R.S. No.	DESCRIPTION	DATE

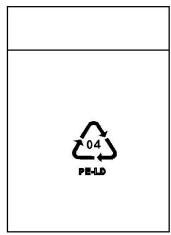

PE袋

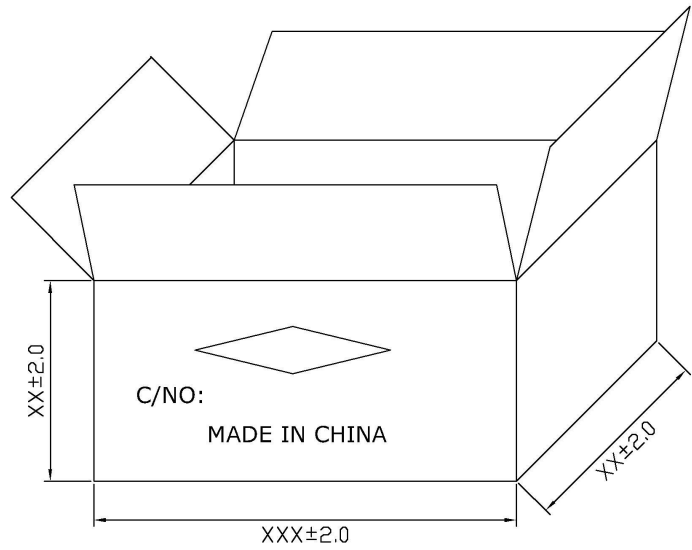
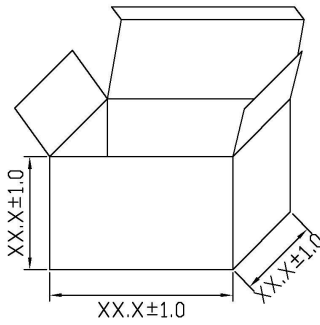

P.O:
 P/N:
 QTY: PCS
 N.W.: KGS
 G.W.: KGS

NOTE:

- 1.1个主机用1个PE袋包装
- 2.PK箱標示尺寸為外部尺寸
- 3.PK箱印前後相同,左右相同,印刷顏色為黑色

 Merryking 深圳市鉅博电子有限公司 SHENZHEN MERRYKING ELECTRONICS Co., Ltd.		顏色 COLOUR	黑色	比例 SCALE	1:1
		料号 P/N		单位 UNIT	mm
绘图 DWG.BY.	校对 CHK.BY.	承认 APP.BY.	名称 NAME	MK-E0000000	修改 REVISION
Cloud			图号 DWG NO.	MK-202008-01	日期 DATE
					20.07.28

EDITION
版本
A0